

# BACKCOUNTRY TOUGH

Your go-anywhere adventure



**Extremely Durable and Light Weight  
MT Composite Propeller**

**mt-propeller**

### Nose Gear Gravel Deflector

Protect your cargo pod from costly rock damage

- Deflect rocks from belly, antennas, and cargo pod
- For maximum equipment protection, install the Main Gear Gravel Deflector and the Nose Tire Scraper
- Also great for operating from paved surfaces!



Manufactured by AeroTwin

Aircraft	P/N
<b>Cessna</b>	
206, 206H, T206H <sup>1</sup> , P206, P206A,B,C,D,E <sup>1</sup> , TP206A,B,C,D,E <sup>1</sup> , TU206A,B,C,D,E,F,G <sup>1</sup> , U206, U206A,B,C,D,E,F,G <sup>1</sup>	NGD6-100
208, 208B	NGD8-100
<b>Quest/Daher</b>	
Kodiak 100	NGDQ-100
Notes:	
<sup>1</sup> Only approved with the Airglas large nose fork	

### Floatplane Steps and Handles

Safely climb onto your aircraft with P/N FP8-100  
Provides access to the top of the wing for fueling without a ladder.

- Easily and safely fuel your aircraft
- Designed for floatplanes, but can be used on land-based 208 aircraft
- Only applicable for 208 model
- Acceptable Alternate Method of Compliance (AMOC) to AD 2006-01-11 for 208's not approved for flight into known icing



Manufactured by AeroTwin

### Main Landing Gear Gravel Deflector

Prevent damage to the stabilizer and aft fuselage

- Deflect rocks from stabilizer and fuselage
- Keep mud, snow, and rocks off of your wings
- Installation requires no additional holes in the structure



Aircraft	P/N	Applicable w/ STC Installed
<b>Cessna</b>		
180, 180A,B,C,D,E,F,G,H,J,K	GD5-100	SA02022AK
182, 182A,B,C,D,E,F,G,H,J,K,L,M,N,P,Q <sup>2</sup>	GD5-102	
185, 185A,B,C,D,E, A185E,F	GD5-105	SA4622NM
P206, P206A,B,C,D,E <sup>1</sup> , TP206A,B,C,D,E <sup>1</sup> , TU206A,B,C,D,E,F,G <sup>1</sup> , U206, U206A,B,C,D,E,F,G <sup>1</sup>	GD6-100	
	GD6-200	
207, 207A, T207, T207A	AT-GD-1001	SA4623NM
208, 208B	GD8-100	
<b>Quest/Daher</b>		
Kodiak 100	GDQ-100	
Notes:		
<sup>1</sup> For big tires, use P/N GD6-200		
<sup>2</sup> S/N 33000 thru 18266590		

Manufactured by AeroTwin

### Nose Tire Scraper

Shield your propeller from gravel, sand, and water damage!

P/N ATI-208TS fits Caravan 208, 208B with STC SA2335NM installed  
P/N TSQ-100 fits Quest/Daher Kodiak 100

- Easily install in under 20 minutes
- Rubber scraper knocks rocks out of the tire tread to keep them from being flung forward though the prop
- Replacement rubber scrapers are available



Manufactured by AeroTwin

**Ice Inspection Handle**  
P/N 208-ICE-HNDLE

- Save \$\$\$
- Complies with AD 2006-01-11

Manufactured by AeroTwin



**Tail Slide Abrasion Guard**  
P/N TAIL SLIDE ABRASION GUARD

Guards the Tail Slide section most affected by damage

- Abrasion-resistant steel
- Ideal for flight training purposes



Manufactured by Middle Fork Mods

**Entry Step**  
Stronger and corrosion resistant  
P/N 8013-01

- FAA-PMA approved
- Left and right step are universal
- Reinforced corner for strength
- Powder coated white

FAA-PMA Approved Aircraft
170 thru 170B
180 thru 180F
185 thru 185E

Manufactured by F Atlee Dodge

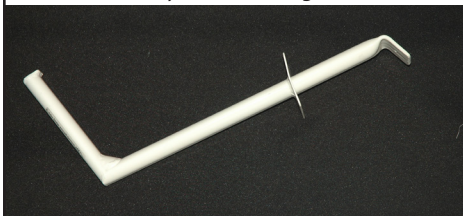

**Tail Slide**

STC approved for Cessna aircraft

Protect your aft bulkhead in the case of an accidental tail strike! Perfect for flight training and rough fields

- Made from high-strength aluminum
- Epoxy-primed and ready for paint!
- Tail Slide Abrasion Guard available separately

**Prevents tail cone and bulkhead damage**



Stencils included

Manufactured by Middle Fork Mods

Aircraft	P/N
172, 172A,B,C,D,E,F,G,H,I,K,L,M,N,P,Q,R,S, 172RG, F172D,E,F,G,H,K,L,M,N,P, F172P, FP172, FR172E,F,G,H,J,K, R172E,F,G,H,J,K, P172D	TAIL SLIDE 172 KIT
175, 175A,B,C	TAIL SLIDE 172 KIT
182, 182A,B,C,D,E,F,G,H,J,K,L,M,N,P,Q,R,S,T, R182, T182, T182T, TR182	TAIL SLIDE 182-210 KIT
210-5 (205), 210-5A (205A)	TAIL SLIDE 182-210 KIT
206, 206H, T206H, P206, P206A,B,C,D,E, TP206A,B,C,D,E, TU206A,B,C,D,E,F,G, U206, U206A,B,C,D,E,F,G	TAIL SLIDE 182-210 KIT
207, 207A, T207, T207A	TAIL SLIDE 182-210 KIT
210, 210A,B,C,D,E,F,G,H,J,K,L,M,N,R, P210N,R, T210F,G,H,J,K,L,M,N,R	TAIL SLIDE 182-210 KIT

**Boot Cowl Handle**

Slightly larger to accommodate gloves!

P/N 3354H

180H,J, A185E,F, U206/TU206A,B,C,D,E,F,G, P206/TP206A

- May not match up with existing bolt pattern due to alternate styles used by OEM
- Undrilled
- Replacement for P/N 0713191-1
- FAA-PMA

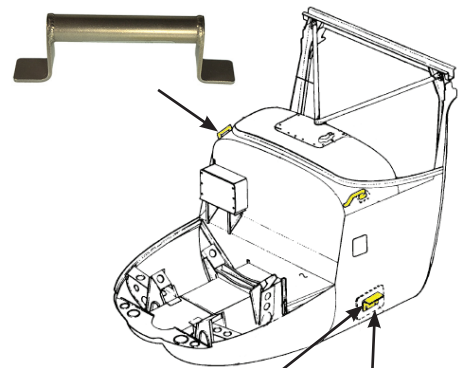

**Boot Cowl Step**

Larger size to accommodate hunting and fishing footwear!

P/N 3354S

U206/TU206A,B,C,D,E,F,G, P206/TP206A

- Undrilled
- White powder coating
- 2 per aircraft
- Direct replacement for P/N 124022-5
- FAA-PMA



**Boot Cowl Doubler**

P/N 3354D

Doubler P/N 3354D is a convenience item useful for reinforcing the mounting locations for P/N 3354H and 3354S Boot Cowl Handles and Steps. For mounting locations that do not have enough clearance for the doubler the installer must rely on existing stringers, other existing structure, and/or a custom fabricated doubler. It is up to the installer to verify the structural integrity of the attachment.

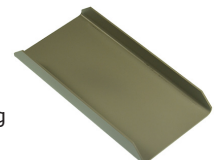

Manufactured by F Atlee Dodge

FAA-PMA Approved

**V Brace Assembly**

**Durable, High Quality Construction!**

FAA-PMA approved for Cessna 180 thru 206 models

- Thicker baseplate and feet to prevent cracking
- Stainless steel
- Save \$\$\$
- Longer service life

Aircraft	P/N
180, 180A,B,C,D,E,F,G	180VBE <b>1</b> AD0513003-19
180H,J,K	AD0713103-2
185, 185A,B,C	AD0513003-19
A185E,F	AD0713103-2
206, U206, T206A-G, U206A-G	AD1242001-18
207, T207	AD1242001-18

**Notes:**

**1** 180, 180A,B only

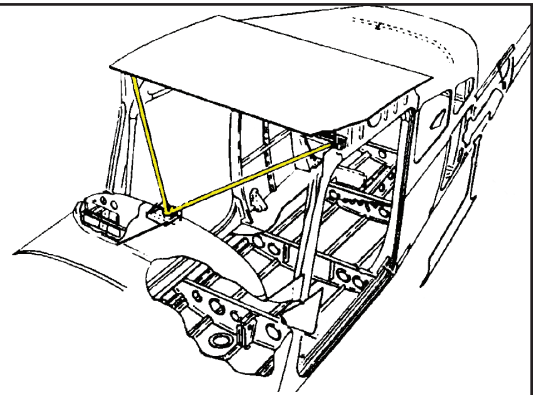
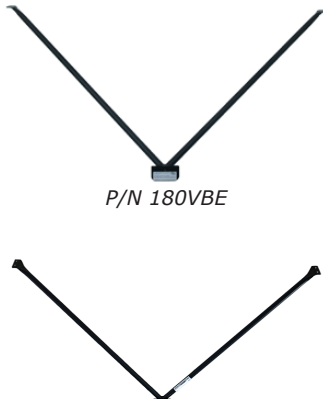

Manufactured by F Atlee Dodge

**Folding Rear Seats**

**Convert from people to cargo in just a few minutes!**  
**P/N 3187 (includes the left and right seats)**

170 thru 170B, 172 thru 172S, 175 thru 175C,  
 180 thru 180K, 182 thru 182D

**P/N 3187-182E **1** (includes the left and right seats)**

**1** FAA Approval Pending

182E thru 182T, 185 thru A185F

The FAA-PMA/STC approved folding rear seats replace the existing bench seat and increase the flexibility and utility of your airplane. The seats can be independently folded forward, stowed to the side, or totally removed in minutes to allow cargo and passenger configurations.

- Easy access to baggage
- Easier access to the tail cone for maintenance
- Increased payload! About 20 pounds lighter than the original bench seat

**Frees wasted space**

The original bulky bench seats take nearly twice as much floor space as the compact, yet comfortable folding seats.

- 50% more baggage space
- More leg room



**20 Pounds Lighter!**

**Convenient installation kit**

Seats are sold in pairs (left and right) as a kit with all required installation hardware, including mounting tracks that attach to the floor and side door frame. (Seat belts, upholstery, cushioning, and stowage straps/bungees not included).

**Upholster to match your interior**

This is not a "jump seat" or "utility seat". You don't have to sacrifice comfort and style. Seats provide room for a cushion and upholstery up to 2 inches thick. Match your interior for an attractive and comfortable finish.



Manufactured by F Atlee Dodge

**Heavy Duty Seat Back Frame**

**Heavy Duty - 10 oz. heavier with less tendency to wear out!**

**P/N 3226**

Replaces P/N 1214012-1 and 1214012-4  
 FAA-PMA approved for Cessna 206 aircraft



Manufactured by F Atlee Dodge

**Firewall Mounted Battery Rack**

**Easier access and less weight!**  
**P/N 8008**

**Quick and easy mounting**

The Firewall Mounted Battery Rack mounts on the firewall on existing stringers or channels, allowing for quick and easy mounting and easier servicing with no extra support required.

**Shorter wiring**

With shorter wiring, power loss from long wires is eliminated and starting is improved.

- Designed for Lightweight Dry Cell Battery, P/N 0769-4005
- FAA-PMA/STC approved

**Saves 19 Pounds!**

Manufactured by F Atlee Dodge

**Model**

150K, A150L, F150K, FA150K
170, 170A,B
172B,C,D,E,F,G,H,I,K,L,M,N,P
F172D,E,F,G,H,K,L,M,N,P
R172E,F,G,H,J,K
175, 175A,B,C
180, 180A,B,C,D,E,F,G,H,J,K
182, 182A,B,C,D,E,F,G,H
185, 185A,B,C,D,E, A185E,F



**Lightweight Dry Battery: 680 Amps**

**Superior vibration resistance**  
**P/N 0769-4005**

- Big power in a little box
- Leak proof, high G rated
- 6 to 10 year service life
- Can be used with battery rack  
 P/N 3304 or 8008
- FAA-PMA and FAA-STC

**Saves 15 Pounds!**



Manufactured by EnerSys Energy Products

**Oil Filters, Spark Plugs, and Air Filters**

**Available for Cessna, Piper, Maule, and more**

See Firewall Forward section of the catalog for aircraft eligibility



Manufactured by Tempest

**Cargo Tie Down**

Secure your cargo  
**TDC-208**

FAA-PMA/STC approved for Cessna 208 and Piper PA-31 models  
Clamps to seat rails to provide tie down points to secure cargo

- 4 required for every 100 lbs of cargo
- Anodized aluminum for durability



P/N TDP-31



P/N TDC-208

Manufactured by F Atlee Dodge

Model	Part Number
<b>Cessna</b>	
208, 208A,B	TDC-208
<b>Piper</b>	
PA-31, PA-31-300,325,350, PA-31P, PA-31P-350, PA-31-T, PA-31-T1, PA-31-T2, PA-31-T3	TDP-31

Note: This product is not to be used as a seat stop.

**Extended Baggage Kit for PA-18 "150" Series**

No welding required - Extends baggage area by almost 3 feet!  
**P/N 2103**

- FAA-PMA/STC approved for most PA-18 aircraft
- Requires PA-18 "150" fuselage or equivalent previously approved 1750 lb gross weight modification at longitudinal station 99.0
- No welding required, may be assembled with blind or solid rivets
- Approx. compartment dimensions: 14" high X 15" wide X 35" deep
- Rated for 20 lbs of baggage

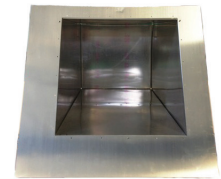
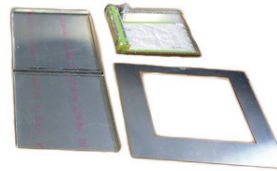
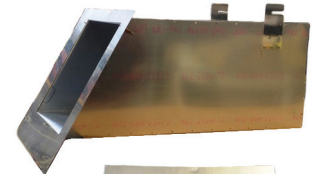
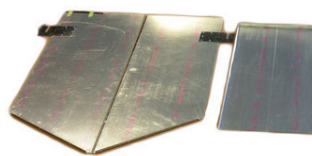

End view

Manufactured by F Atlee Dodge

**Weld-In Extended Baggage Kit for PA-18 and PA-19 Series**

Large volume for bulky, light-weight cargo!

**P/N 6201**

- FAA-STC approved for PA-18 and PA-19 aircraft
- Weld-In modification consisting of steel support frame and support tabs
- Great for storing wing covers, engine blankets, sleeping bags, paragliding sails and more
- Approximate dimensions: 22-1/2" wide at the front X 17-1/2" wide at the back X 43-1/2" deep
- 10 lb maximum load

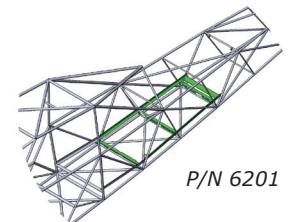

P/N 6201

**Inverted Dogleg STC for PA-11, PA-12, PA-18 and PA-19 Series**

Makes loading baggage easier! STC SA02436AK

- Relocates the diagonal tube to the upper right corner
- FAA/STC approved for PA-11, PA-12, PA-18 and PA-19 aircraft
- Allows easy access to the aft baggage area from the baggage door
- No more catching your gear when removing it from the extended baggage area
- Longer cargo can be placed at an angle for easier insert/removal through the baggage door

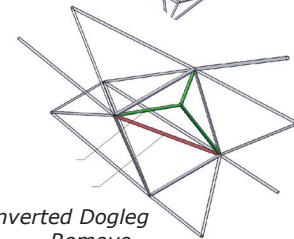

Inverted Dogleg Remove

Manufactured by F Atlee Dodge

**Heavy Duty Main Landing Gear**

2000 lb gross weight model  
FAA-PMA/STC approved

PA-18 and PA-19

**Make sure your landing gear can take the abuse!**

**Standard Height Gear**

- 1-1/4" axle use P/N 3225-1 (LH) and 3225-2 (RH)
- 1-1/2" axle use P/N 3225-1A (LH) and 3225-2A (RH)

**3" Extended Height Gear**

- 1-1/4" axle use P/N 3284-1 (LH) and 3284-2 (RH)
- 1-1/2" axle use P/N 3284-1A (LH) and 3284-2A (RH)

The 3" extended landing gear gives more height and prop clearance, which is especially important for sand or gravel landings. Powder coat finish. Also available with Epoxy primer, Gloss White, or 20% Semi-gloss for additional charge.



**Note:**

Can be used on models J-3, PA-11,12,14, but requires another STC mod involving additional parts and welding. Call for more information.

FAA Approval Pending

Manufactured by F Atlee Dodge

**Aircraft Tie-Down Brackets for PA-12, PA-18 Series**

Prevents failure at the lift strut attach point  
**P/N 3197**

Designed to take the load off the attach point

- Sold individually
- Uses 2 per aircraft
- FAA-PMA/STC approved



Manufactured by F Atlee Dodge

**Cabane Vee**

Alaska tough!  
**P/N 3166-1 and 3166-2**

FAA-PMA/STC approved for Piper

- Beefed up in the right places
- Tough powder coat finish
- Available in Gloss White for additional charge
- 2 sizes: stock and 3" extended gear



Manufactured by F Atlee Dodge

Model	Part Number
PA-12, PA-12S	3166-2
PA-14	3166-2
PA-18, PA18-105, PA-18-125, PA-18-135, PA-18-A135, PA-18-150, PA-18-A150	3166-1

FAA-PMA Approved

Backcountry Products

**Main Gear Shock Struts**

**Heavy duty, but lightweight!**

Uses (2) per aircraft, sold individually

- PA-12, PA-12S, PA-14, PA-18, PA-18-135, 150, PA-18-A135, A150, PA-18 with standard landing gear use **P/N 3164-1**
- PA-12, PA-14 with standard landing gear use **P/N 3164-2**
- PA-18 with 3" ext. landing gear use **P/N 3164-3**
- PA-12, PA-14 with 3" ext. landing gear use **P/N 3164-4**
- For standard or 3" extended landing gear
- Powder coat finish; also available with Epoxy primer, Gloss white, or "Wolf Hunter" Black for additional charge



Manufactured by F Atlee Dodge

**Safety Cables**

**Don't let a bungee failure cost you an airplane!**



Model	Part Number
PA-12, PA-12S, PA-14	2089-12 <sup>1</sup>
	3344-12 <sup>2</sup>
PA-18 and PA-19	2089-18 <sup>1</sup>
	3344-18 <sup>2</sup>

**Notes:**

- <sup>1</sup> With standard gear use
- <sup>2</sup> With 3" extended gear use

**Heavy 1/4" cable will get you home!**

Manufactured by F Atlee Dodge

**Spar Reinforcing Strut Bracket**

**Spreads out lift strut spar loading**

**P/Ns 3192-12 and 3192-18**

PA-12, PA-14 series use **P/N 3192-12**

PA-18, PA-19 series use **P/N 3192-18**

Protrudes out of wing and attaches to lift strut. Prevents spar flex by reinforcing the front.

- Install during wing maintenance
- Stainless steel construction, powder coated white
- FAA-PMA/STC approved



Manufactured by F Atlee Dodge

**Refueling Step**

**No more step ladders**

**P/N 3190/-10, 3190/-11, 3190/-12**

**FAA-PMA/STC**

J3C-65, J3F-50, J3F-60, J3F-65, J-3L, J3L-65, J-4, J-4A, J-4B, J-5A, J5C, PA-11, 12, 14, 15, 16, PA18-105, 125, 135, A-135, 150, A-150, PA-19, PA-20, PA-20-115, PA-20-135, PA-22-108, 135, 150, 160

Clamps onto main gear leg for easier refueling

Select P/N by landing gear front tube OD:

- 1.25" OD use **P/N 3190/-10**
- 1.375" OD use **P/N 3190/-11**
- 1.5" OD use **P/N 3190/-12**

Powder coated white. Available 20% Semi-gloss for additional charge.



**Rear Seat Heater for PA-18 Series**

**A must for winter flying**

**Alaska proven!**

**P/N 3175**

- Heater modification using warm exhaust heat to heat back seat
- Requires some modification to the firewall
- Complete with firewall valve and control
- FAA-PMA/STC approved

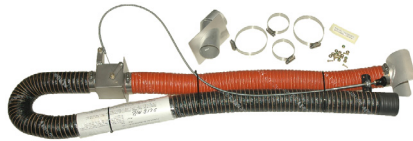

Log book entry only; no FAA 337 form required

Manufactured by F Atlee Dodge

**Under Seat Battery Rack for PA-18 and PA-19**

**Easy battery removal**

**P/N 3304**

Mounts under front seat for easy removal and warm-up of battery.

- Uses FAA-PMA Battery P/N 0769-4005
- FAA-PMA/STC approved

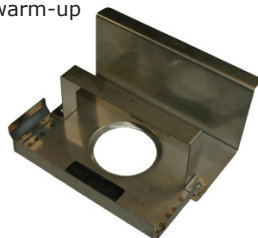

**Saves 15 Pounds!**

Manufactured by F Atlee Dodge

**Main Gear Long Step**

**Easy clamp-on modification**

**Much easier cabin entry**

**P/N 3195**

AE-1, HE-1, J3, J4, J5, PA-11, PA-12, PA-14, PA-18, PA-19

The Main Landing Gear Long Step is usable on both sides of the aircraft as an entry step or refueling step.

Heavy tube with 3 sizes of clamps.

- A must for bush gear and tires
- Alaska tested
- Durable non-skid surface stays on
- Powder coated white for durable corrosion resistance
- FAA-PMA/STC approved

Available in 20% Semi-gloss at no additional charge



Manufactured by F Atlee Dodge

**Safari Seat for PA-18 and PA-19 Series**

**P/N 6151**

**Easily installed and removed**

Clamps in and designed for easy removal with quick release pins.

**Weight saver**

Lightweight folding rear seat saves 10 pounds over existing seat. FAA-PMA/STC

**Folding rear seat!**

**Saves 10 Pounds!**



Manufactured by F Atlee Dodge

**Folding Front Seat and Seat Kit for PA-18 and PA-19 Series**

**Makes entry and loading much easier!**

**P/N 3186-1A**

STC direct replacement and bolt in replacement seat



**P/N 3186-KIT**  
FAA-PMA/STC kit to modify your seat



Manufactured by F Atlee Dodge

**Removable Rear Seat Crossbar**  
**Makes loading easy**  
**P/N 3146-1**  
 PA-18-105, 125, 135, 150, PA-18S-105, 125, 135, 150, PA-19S, PA-19

- FAA-PMA/STC approved
- Install instructions, pins, and blocks included



*Manufactured by F Atlee Dodge*

**Pilot Seat Belt Attachment Kit**  
**Weld on front seat belt attach kit!**  
**P/N 3246**  
 PA11, PA11S and PA18 series aircraft

- Relocates seat belts to floorboard
- Secures pilot seat to fuselage in the event of an accident
- FAA-PMA



*Manufactured by F Atlee Dodge*

**Brake Reinforcing Channel for PA-18**  
**No more cracking!**  
**P/N 4231**

- Made with 4130 steel for durability
- Located under the brake system and the front seat (the brake pedal is attached to the brake channel)



*Manufactured by F Atlee Dodge*

**Firewall, Stainless Steel and Titanium**  
**P/N 8007-01 for Stainless Steel**  
**P/N 8007-02 for Titanium**  
 PA-18, PA19, and PA19S Series

- Replaces P/Ns 12365-003, 12365-005, 12365-007 and 12365-009
- Titanium is 2.8 pounds lighter than stainless steel



*Manufactured by F Atlee Dodge*

**Upper and Lower Cowl Channel for PA-18**  
**No More Rust or Vibration**  
**Upper P/N 3276**  
**Lower P/N 3277**

- Stainless steel - Eliminates rust and vibration failure
- No pre-drilled holes, allowing for a precise fit
- Sold individually: (2) upper and (2) lower required per aircraft
- FAA-PMA



*Manufactured by F Atlee Dodge*

**Front and Rear Shoulder Harness Attach Bracket**  
**Make your Cub safer!**  
**Front Bracket P/N 3232-1**  
**Rear Bracket P/N 3232-2**  
 FAA-PMA for J-3C, 3F, 3L, J-5A,5B, 5C, PA-11, PA-11S, PA-12, PA-12S, PA-18

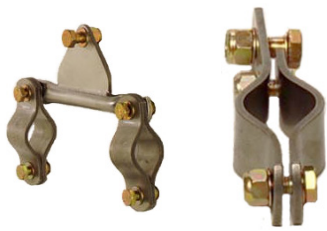

*Manufactured by F Atlee Dodge*

**Oversize Rudders and Elevators**  
**Increased control authority!**  
**P/N AD157260S (rudder)**  
**P/N AD127700S (elevator)**

PA-12, PA-12S, PA-14, PA-18 Series, PA-19S

- Approximately 12% larger
- Powder coated grey with bushings installed
- FAA-PMA/STC approved

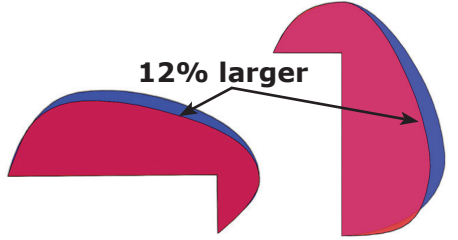

*Manufactured by F Atlee Dodge*

**Silver Aircraft Ski Spring**  
**Consistent tension regardless of temperature**  
**P/N 2097**  
 J3, PA-11, PA-12, PA-14, PA-18, PA-19, PA-20, PA-22

- Replaces ski bungee
- FAA-PMA/STC approved



*Manufactured by F Atlee Dodge*

**Weld on Float Fittings**  
**Better than cheap copies**  
**P/N 3143-12**  
 PA-12, 12S, PA-14

**P/N 3143-18**  
 PA-18S-125, PA-18AS-125, PA-18S-135, PA-18AS-135, PA-18S-150, PA-18AS-150

Beefy, heavy construction, made from 4130 alloy steel

- Used with Aerocet, Bauman, and EDO floats
- Sold in pairs - FAA-PMA/STC



**Copied but never duplicated!**

*Manufactured by F Atlee Dodge*

**Husky Main Landing Gear**  
**Heavy Duty!**  
**P/N AD45017-501HD**  
**P/N AD45017-502HD**  
 A-1, A1A and A1B series Aviat Husky aircraft

- 1.3 lbs. heavier per side
- Used primarily on aircraft equipped with skis
- Replaces P/Ns 45017-501 and 45017-502



*Manufactured by F Atlee Dodge*

## Custom Solutions

**Engine Controls, Flight Control Cables, Seat Rails, Door Cables, and more**

Customize your length, hardware, color, and other unique specifications

**Perfect for your homebuild or bush aircraft!**

